

instructions for
MODEL CA-32
SOUND CALIBRATOR WITH TIMER



GENERAL DESCRIPTION

The Quest CA-32 Sound Calibrator is a self-contained field calibrator that generates a single-frequency reference sound pressure level of 110 dB at 1000 Hertz for precisely 32 seconds. It quickly and precisely verifies the accuracy of sound measuring instruments and the sensitivity of microphones. The timing feature allows rapid, accurate and easy calibration checks for noise dosimeters where the readout value is based on the amplitude and duration of the acoustic input.

The Calibrator is operated by a single 9-volt transistor battery, and being small in size is fully portable. The unit is primarily intended as a field instrument for on-the-spot accuracy checks of noise dosimeters, but may also be used on sound level meters and other instruments with microphone-type inputs.

The CA-32 consists of a 1000 Hz oscillator, a 32-second timer (crystal controlled), a magnetic acoustic transducer with microphone coupler, and a battery indicator to insure accurate, stable performance. The coupler directly accepts a standard 1-1/8 inch diameter microphone. A separate adaptor is also provided to accommodate a 1/2 inch microphone. Adaptors for other standard size microphones are also available.

SPECIFICATIONS

OUTPUT FREQUENCY: 1000 Hz +3% over full temperature range.

OUTPUT TIME: 32 seconds +0.5%, duration indicated by LED, crystal time base.

OUTPUT AMPLITUDE: Sound pressure level of 110 dB, ref. 20 μ N/m².

ACOUSTIC ACCURACY: +0.4 dB at 20°C and 760 mm Hg.

DISTORTION: Less than 1%.

TEMPERATURE: -10 to +50°C operating. -40 to +65 C storage (battery removed). Coefficient of SPL is -.015 dB/°C to +.015 dB/°C.

RELATIVE HUMIDITY: 0 to 95%, operating within 0.5 dB accuracy.

ALTITUDE EFFECTS: 0.1 dB decrease in sound level output for each 2000 ft. of elevation from sea level to 12,000ft.

POWER: Battery-operated; 9 volt standard transistor battery, NEDA 1604, Burgess 2U6, Eveready 216 or equivalent.

BATTERY LIFE: Approximately 50 hours operation with intermittent use. Cold temperatures near or below freezing greatly reduce effective battery life. Consult battery manufacturer's data for a current drain of 10 milliamps.

CONSTRUCTION: Solid state integrated circuitry in a rugged aluminum housing.

SIZE AND WEIGHT: 4 inch x 2-3/8 inch diameter (10 x 6 cm.) 12 ounces (340 grams).

PRINCIPLES OF OPERATION

The block diagram of the CA-32 depicts the basic operation of the instrument.

The battery indicator continuously monitors the battery condition. When the indicator needle enters the red area during operation, the battery should be replaced. A dual voltage supply is created from the 9 volt battery. The oscillator output is allowed to pass through the output gate to the transducer for precisely 32 seconds. The 32 second gate time is controlled by a crystal oscillator time base.

OPERATING PROCEDURE

The CA-32 Calibrator is designed to check the accuracy of many types of sound instruments in addition to equipment manufactured by Quest. Quest instruments commonly use the standard 1-1/8 inch diameter ceramic microphone which fits directly into the calibrator coupler cavity. The next most commonly used sizes are 1 inch (actually 15/16 inch) and 1/2 inch microphone diameters. For other microphones with smaller diameters, adaptors are available.

Use the following procedure to calibrate a sound level meter or a noise dosimeter with the CA-32:

1. Turn the Calibrator POWER switch to ON.
2. Make sure BATT. indicator is in the GREEN area to insure that the battery is GOOD. If not, replace battery (see BATTERY CHECK AND REPLACEMENT).
3. Insert the proper size microphone adaptor (if needed).

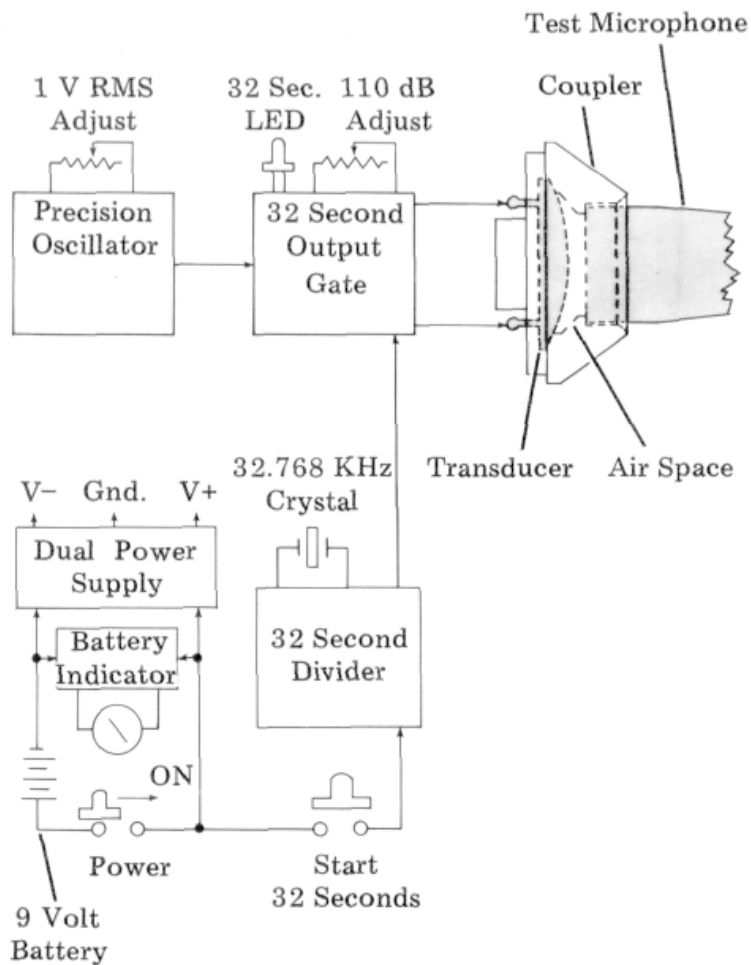

Block Diagram of CA-32 Calibrator With Timer

4. Carefully insert the microphone into the calibrator coupler. Be sure microphone is fully down in the coupler (or adaptor if used). Be sure that the microphone rests squarely on the lower rim to form the necessary inner seal.

CAUTION

Rapid insertion or withdrawal of the microphone may damage the microphone or the transducer in the coupler because of the rapid change in pressure on the diaphragms.

5. Press the START button once. The 110 dB output will last for precisely 32 seconds. Anytime the START button is pressed, the output will last for 32 seconds more. The 32 SEC light will glow during the 110 dB output. When it goes out, the output drops from 110 dB to approximately 65 dB.

6. SOUND LEVEL METER: Verify accuracy by comparing the known output level of the calibrator to the sound level meter reading. Adjust meter calibration as necessary. Be sure to consider altitude correction for the calibrator when adjusting the meter. (See ALTITUDE EFFECTS).

NOISE DOSIMETER: Verify accuracy by comparing dosimeter readouts with the readouts shown in Table 1.

7. After calibration, carefully remove the microphone and move CA-32 POWER switch to OFF.

ALTITUDE EFFECTS

Most acoustic calibrators, including the CA-32, are affected by altitude or atmospheric pressure changes. The

Table 1. Dosimeter Readout Limits for Various Exchange Rates and Criterion Levels

Exchange Rate	Criterion Level 100% – 8 Hrs.	Dosimeter Readout Limits for 110 dB 32 Second Timing		
		Minimum (-1 dB)	Exact	Maximum (+1 dB)
5 dB	85 dB	3.10	3.56	4.08
5 dB	90 dB	1.55	1.78	2.04
4 dB	90 dB	3.00	3.56	4.22
4 dB	84 dB	8.48	10.07	11.93
3 dB	85 dB	28.45	35.84	45.15
3 dB	90 dB	8.96	11.29	14.22

transducer diaphragm within the calibrator coupler creates a sound as it vibrates against the air. In general, when the air is thinner (at higher elevation), a lower sound level is produced by the calibrator.

The CA-32 is set at the laboratory to emit 110 dB at sea level (760 mm Hg). For each 2000 feet of increase in altitude (approximately 50 mm Hg decrease in pressure) up to 12,000 feet, the output decreases approximately 0.1 dB.

BATTERY CHECK AND REPLACEMENT

The CA-32 Calibrator has only one 9 volt transistor battery as its power source.

To test the battery, turn the POWER switch to ON. The BATT. indicator should go into the GREEN area, meaning that the battery is good. If the indicator stays within the RED area, the battery needs replacement.

To replace the battery, first be sure the calibrator is turned OFF. Then remove the two screws on the face plate. Grasp the cylinder housing and gently pull it upward. The cylinder and the face plate should come off together exposing the circuitry and battery. Carefully unsnap the battery clip and pull out the weak battery. Replace with a fresh battery and snap clip on battery properly. Carefully replace the cylinder and face plate so as not to pinch any wires.

CA-32 CALIBRATION

The CA-32 Calibrator was precisely calibrated in the Quest laboratory with special acoustical instrumentation traceable to the U.S. Bureau of Standards. The CA-32 is very stable; but since it is used to calibrate other equipment, it should be periodically checked with laboratory standards. It is recommended that the calibrator be returned to the factory at least once each year for recalibration, or whenever there is a question about its accuracy.

The illustration on page 9 shows the CA-32 calibrator with cylinder sleeve removed. Control potentiometers are indicated for adjusting the oscillator voltage and the transducer output. THESE "POTS" ARE FOR PRECISE LABORATORY CALIBRATION ONLY, AND SHOULD NOT OTHERWISE BE ADJUSTED.

Service Policy

The Quest product you have purchased is one of the finest acoustic instruments available. It is backed by our full one year warranty which seeks complete customer satisfaction. This is your assurance that you can expect prompt courteous service for your equipment from the entire Quest service organization.

Should your Quest equipment need to be returned for repair or recalibration, please contact the Service Department at (800)245-0779 (USA) or Fax (262)567-4047 for a Return Authorization Number. The RA number is valid for 30 days, and must be shown on the shipping label and purchase order/cover letter. If you are unable to return instruments in that time call for a new RA number. Send it prepaid and properly packed in the original shipping carton directly to Quest Technologies, 1060 Corporate Center Drive, Oconomowoc, WI 53066 U.S.A.

Repair or replacement work done under warranty will be performed free of charge, and the instrument will be returned to you prepaid. Your copy or a photocopy of the Quest Registration Card will serve as proof of warranty should the factory require this information.

If for any reason you should find it necessary to contact the factory regarding service or shipping damage, please direct your calls or letters to the attention of the Service Manager, Quest Technologies, (262) 567-9157 or (800) 245-0779. Office hours are from 7 AM to 6 PM (Central Standard Time) Monday through Friday.

For service or recalibration outside the U.S.A., please contact your local Quest Dealer or fax Quest U.S.A. at 1-262-567-4047.

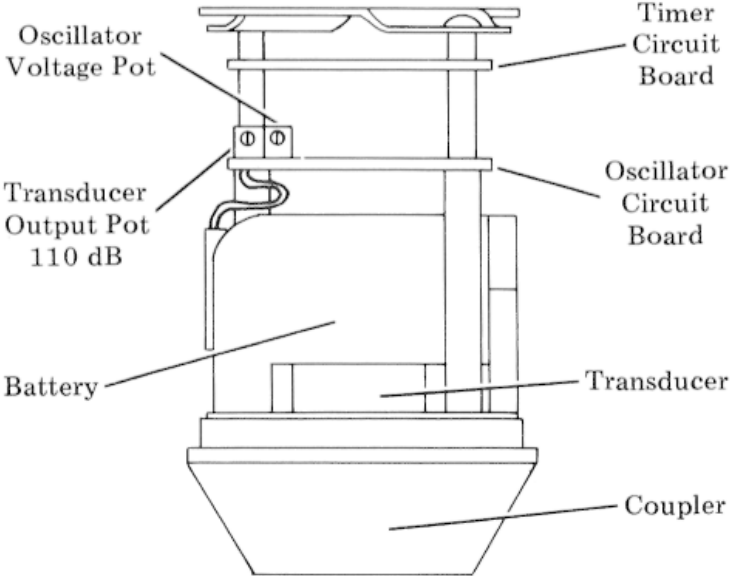

CA-32 Calibrator dB Adjustment Control