

instructions for

**MODEL CA-12A
MODEL CA-12B
MODEL CA-12M**

**SOUND
CALIBRATORS**



MODEL CA-12A MODEL CA-12B MODEL CA-12M SOUND CALIBRATORS

GENERAL DESCRIPTION

The Quest CA-12A, CA-12B, and CA-12M Sound Level Calibrators are self-contained units that quickly and precisely verify the accuracy of microphones and sound measuring instruments. The three calibrators produce a reference sound pressure level at 1000 Hz — the CA-12A at 114 dB, the CA-12B at 110 dB, and the CA-12M at 94 dB.

The units are battery operated and therefore fully portable. They are primarily field instruments for on-the-spot accuracy checks of sound level meters, noise dosimeters and other microphone instruments.

The calibrators consist of a stable 1000 Hz oscillator and magnetic acoustic transducer in a coupler that accepts a standard 1-1/8 inch diameter microphone. Adaptors are available to accommodate other various microphones that are smaller in diameter. See Table 1.

SPECIFICATIONS

STANDARD: ANSI S1.40-1984

OUTPUT FREQUENCY: 1000 Hz \pm 3% over full temperature range.

NOMINAL SOUND PRESSURE LEVEL

CA-12A: 114 dB (10 pascals)

CA-12B: 110 dB (6.3 pascals)

CA-12M: 94dB (1 pascal) Ref. 20 micropascals (20 μ N/m²)

SOUND PRESSURE LEVEL ACCURACY: ± 0.4 dB at 20°C,
101.3 kilopascals (760 mm Hg), and RH of 65%.

DISTORTION: Less than 1% within temperature and humidity
operating ranges.

TEMPERATURE RANGE:

-10 to +50°C operating.

-40 to +65°C storage with battery removed.

TEMPERATURE SENSITIVITY: 0 to 0.01 dB/°C max. ref. 20°C.

HUMIDITY SENSITIVITY: 5 to 95% relative humidity with less
than 0.1 dB change in output.

ATMOSPHERIC PRESSURE SENSITIVITY: Approximately -
.10 dB for each 1000 meters above sea level. See Figure 2.

MAGNETIC FIELD SENSITIVITY:

60 Hz, 80 A/m: + .01 dB max.

400 Hz, 80 A/m: + .01 dB max.

Maximum additional distortion is not more than 1%.

POWER: Battery operated, 9 volt transistor battery, NEDA 1604
type. Battery will provide at least 50 hours of operation.

SIZE AND WEIGHT: 10 cm (4 inches) long, 6 cm (2.4 inches)
diameter, 340 grams (12 ounces).

PRINCIPLES OF OPERATION

The block diagram in Figure 1 depicts the basic operation of
the instrument.

The battery indicator continuously monitors the battery
condition. When the indicator needle enters the red area during
operation, the battery should be replaced.

The precision 1 kHz oscillator is a wien-bridge type for high
stability and low distortion. Automatic gain control (AGC) and
temperature compensation are incorporated in the oscillator
design. The oscillator AC output is precisely set at 1 V rms. The
sound pressure level is then adjusted for the correct acoustical
output. This method produces a very stable oscillator output
over both decaying battery voltage and changing temperature.

OPERATING PROCEDURE

The coupler cavity of the calibrator is designed to accept a
1-1/8 inch diameter microphone directly. The proper adaptor
must be used for microphones that are smaller in diameter than
the 1-1/8 inch coupler opening. See Table 1.

1. If an adaptor is needed, carefully slide the adaptor onto
the microphone.

CAUTION

Pull the adaptor onto the microphone by grasping the
sides of the adaptor. Do not use the palm of the hand to
push the adaptor onto the microphone as serious
damage will possibly occur to the microphone dia-
phragm due to pressure build-up!

2. Slowly place the microphone (or microphone with
adaptor) into the calibrator coupler.

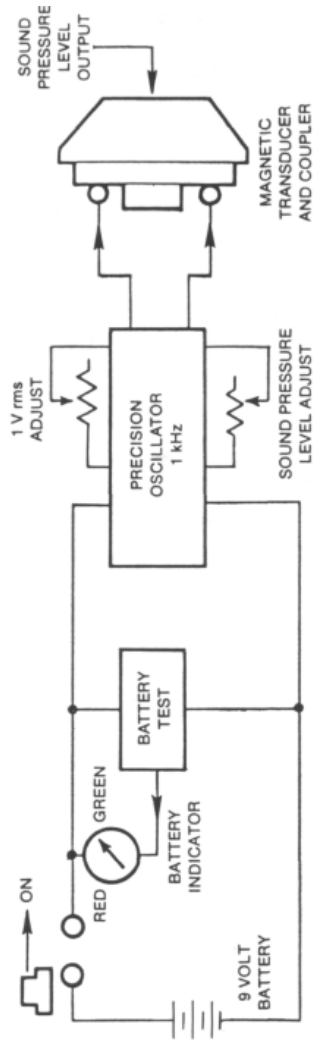

Figure 1. Block Diagram of Calibrator

CAUTION

Rapid insertion or withdrawal of the microphone may damage the microphone or the coupler transducer because of the rapid change of pressure on the diaphragms.

3. Set the calibrator switch to "ON." Be sure that the "BATT." indicator enters the green area. If not, see BATTERY CHECK AND REPLACEMENT.
4. Proceed to verify the test instrument accuracy by following the calibration procedure specified in the instrument manual.

NOTE

If the test location is more than 3000 feet (1 kilometer) above sea level, it is a good procedure to determine the correction for the calibrator output using the Altitude/Barometric Pressure Correction Chart in Figure 2.

5. When calibration has been made, carefully remove the calibrator and turn it "OFF."

ATMOSPHERIC PRESSURE SENSITIVITY

Most acoustic calibrators, including Quest calibrators, are affected by altitude and atmospheric pressure changes. The transducer diaphragm within the calibrator coupler creates a sound as it vibrates against the air. In general, when the air is thinner (at higher elevations), a lower sound pressure level is transmitted through the less dense air to the microphone diaphragm.

By either using a barometer or knowing the elevation above sea level, output corrections can be made using the Altitude/Barometric Pressure Correction Chart in Figure 2.

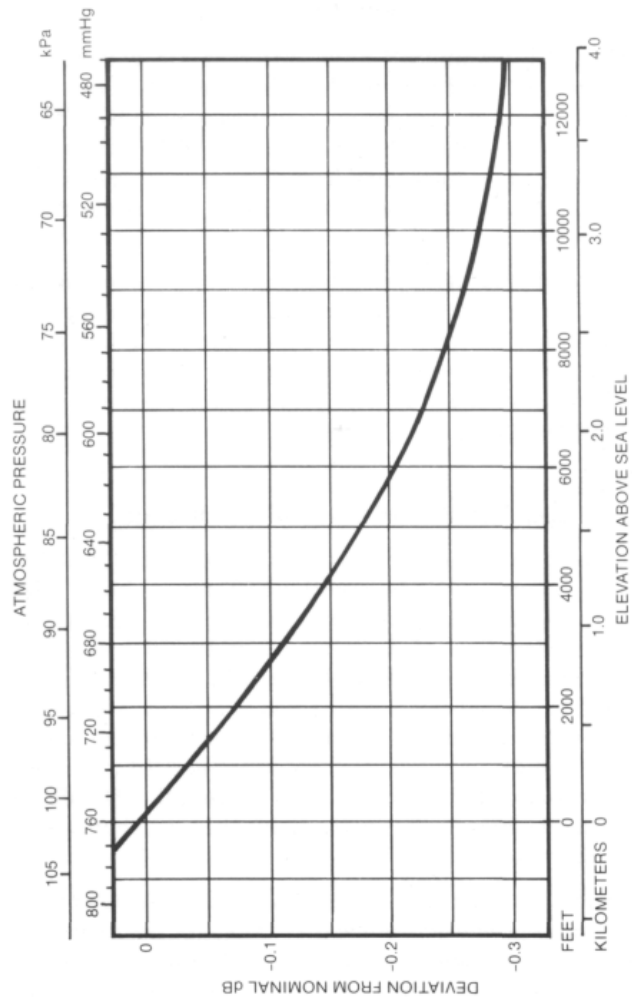

Figure 2. Altitude/Barometric Pressure Correction Chart

MICROPHONE CORRECTIONS

Different microphones have different air volumes between the grid and the diaphragm. They also have diaphragms of various compliance (stiffness). Because of these conditions, the generated sound pressure level at the microphone diaphragm may vary from the nominal level of the calibrator. A correction is thus necessary for some microphones.

The sound pressure level values for some common instrumentation microphones are listed in the Microphone Correction Chart, Table 1. These numbers are valid only when using any of the three Quest calibrators (with Quest microphone adaptors if needed) to perform calibration on the listed microphones.

EXAMPLES OF CALIBRATOR USE

Example 1. Assume that you are calibrating the Quest 155 Precision Sound Level Meter with a 1/2" microphone (7046 or 7047) at a barometric pressure of 530 mm Hg, corresponding to an elevation of approximately 10,000 feet (3,000 meters). From the Microphone Correction Chart, use Quest adaptor Part Number 58-928. If you are using a CA-12M calibrator, the sound pressure level imparted to the microphone is 94.0 dB at sea level. Then use the Altitude/Barometric Pressure Correction Chart to correct the 94.0 dB to 93.7 dB at 10,000 feet. This is the value that the sound level meter shall read.

Example 2. Assume that you are calibrating a meter with a GR P5 microphone at Denver, Colorado with an elevation of 5,200 feet (1,600 meters). Using the Microphone Correction Chart, the proper adaptor is Quest Part Number 58-929.

Table 1. Microphone Correction Chart

Microphone (with grid)	Dia. (inches)	Quest Adaptor	Sound Pressure Level (dB) at Sea Level (101.3 kPa)		
			CA-12A	CA-12B	CA-12M
WE 640AA	.936	58-929	114.3	110.3	94.3
B&K 4160	.936	58-929	114.3	110.3	94.3
B&K 4144	.936	58-929	114.0	110.0	94.0
B&K 4133	.52	58-928	114.0	110.0	94.0
B&K 4165	.52	58-928	114.0	110.0	94.0
GR P ₃ , P ₄	1.125	NONE	114.0	110.0	94.0
GR P ₅ , P ₆	.936	58-929	114.2	110.2	94.2
GR 1961	.936	58-929	114.3	110.3	94.3
GR 1962	.50	58-927	113.8	109.8	93.8
Quest 1845	.31	58-839	114.0	110.0	94.0
Quest 1830	.50	58-927	114.0	110.0	94.0
Quest 401	1.125	NONE	114.0	110.0	94.0
Quest 7046/47	.52	58-928	114.0	110.0	94.0
Quest 7013	.52	58-928	114.0	110.0	94.0
Quest 7023	.936	58-929	114.0	110.0	94.0
Quest M60-261	.725	58-877	*	110.0	94.0
Quest EM-60B	.39	58-386	114.0	110.0	94.0

*114 dB exceeds range of microphone.

If you are using a CA-12B calibrator, the sound pressure level imparted to the microphone is 110.2 dB at sea level. Then use the Altitude/Barometric Pressure Correction Chart to correct the 110.2 dB to 110.0 dB at 5,200 feet. This is the value that the sound level meter shall read.

For most applications, the Altitude/Barometric Pressure correction can be omitted since the maximum change at 13,000 feet is only -0.3 dB. Also, when using all Quest micro-

phones with their associated adaptors, the microphone correction chart is not needed since the chart value exactly agrees with the dB output stated on the calibrator.

Use of microphones other than those listed in Table 1 is not recommended and should be done with caution since calibration errors could exist.

BATTERY CHECK AND REPLACEMENT

Each calibrator has one 9-volt transistor battery as its power source.

To test the battery, turn the switch to "ON." The "BATT." indicator should go into the GREEN area, meaning that the battery is good. If the indicator remains within the RED area, the battery must be replaced.

To replace the battery, first be sure that the calibrator is turned to "OFF." Then remove the two screws on the face plate. Grasp the cylinder housing and gently pull it upward. The cylinder and face plate will come off together exposing the circuit and battery. Carefully unsnap the battery clip and pull out the weak battery. Slide a new battery into the holder with the smaller snap (+) towards the transducer (see Figure 3). Then snap the battery clip onto the battery. Carefully replace the cylinder and faceplate so as not to pinch any wires. Replace the two screws.

CALIBRATION ADJUSTMENTS

The Quest Calibrator was calibrated at the Quest laboratory using a type L transfer microphone with calibration traceable to the U.S. National Bureau of Standards.

A Quest calibrator is very stable; but since it is used to calibrate other equipment, it should be checked periodically

against laboratory standards. It is recommended that the unit be sent back to the Quest laboratory at least once each year for recalibration, or whenever there is a question about its accuracy.

The unit should be shipped in a well-padded container to avoid damage in shipping.

Figure 3 depicts the calibrator with the cylinder removed. Control potentiometers are indicated for adjusting the oscillator voltage and the transducer output. THESE "POTS" ARE FOR PRECISE LABORATORY CALIBRATION ONLY, AND SHOULD NOT BE READJUSTED BY THE USER.

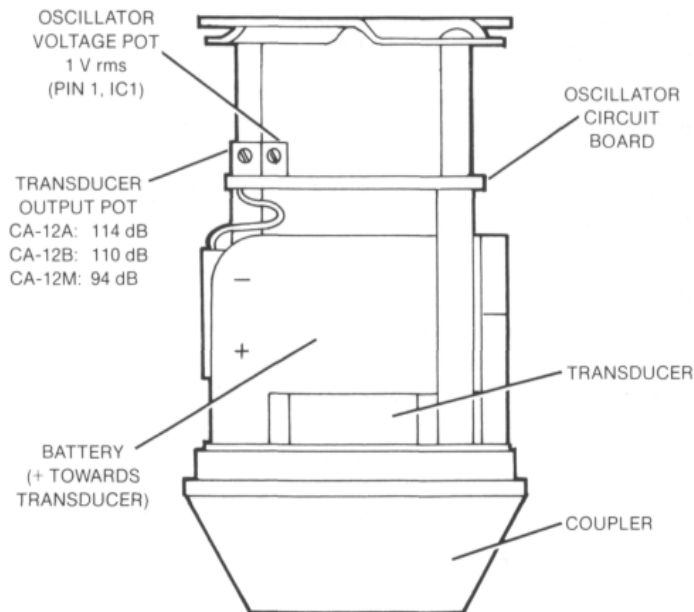

Figure 3. Calibrator Adjustment Controls

Service Policy

The Quest product you have purchased is one of the finest acoustic instruments available. It is backed by our full one year warranty which seeks complete customer satisfaction. This is your assurance that you can expect prompt courteous service for your equipment from the entire Quest service organization.

Should your Quest equipment need to be returned for repair or recalibration, please contact the Service Department at (800)245-0779 (USA) or Fax (262)567-4047 for a Return Authorization Number. The RA number is valid for 30 days, and must be shown on the shipping label and purchase order/cover letter. If you are unable to return instruments in that time call for a new RA number. Send it prepaid and properly packed in the original shipping carton directly to Quest Technologies, 1060 Corporate Center Drive, Oconomowoc, WI 53066 U.S.A.

Repair or replacement work done under warranty will be performed free of charge, and the instrument will be returned to you prepaid. Your copy or a photocopy of the Quest Registration Card will serve as proof of warranty should the factory require this information.

If for any reason you should find it necessary to contact the factory regarding service or shipping damage, please direct your calls or letters to the attention of the Service Manager, Quest Technologies, (262) 567-9157 or (800) 245-0779. Office hours are from 7 AM to 6 PM (Central Standard Time) Monday through Friday.

For service or recalibration outside the U.S.A., please contact your local Quest Dealer or fax Quest U.S.A. at 1-262-567-4047.